

Pendulum System Components

Your Pendulum Conveyor System is used for both Pre-Treatment (Phosphate) and Electro-Coating Paint Operation (E-Coat, ELPO) processes and contains the following major components:

- Skid/Body Lock/Unlock
- Pendulum Inlet Table
- Pendulum Outlet Table
- Pendulum Chain
- Pendulum Drive Assembly
- Pendulum Take-Up
- Penduls

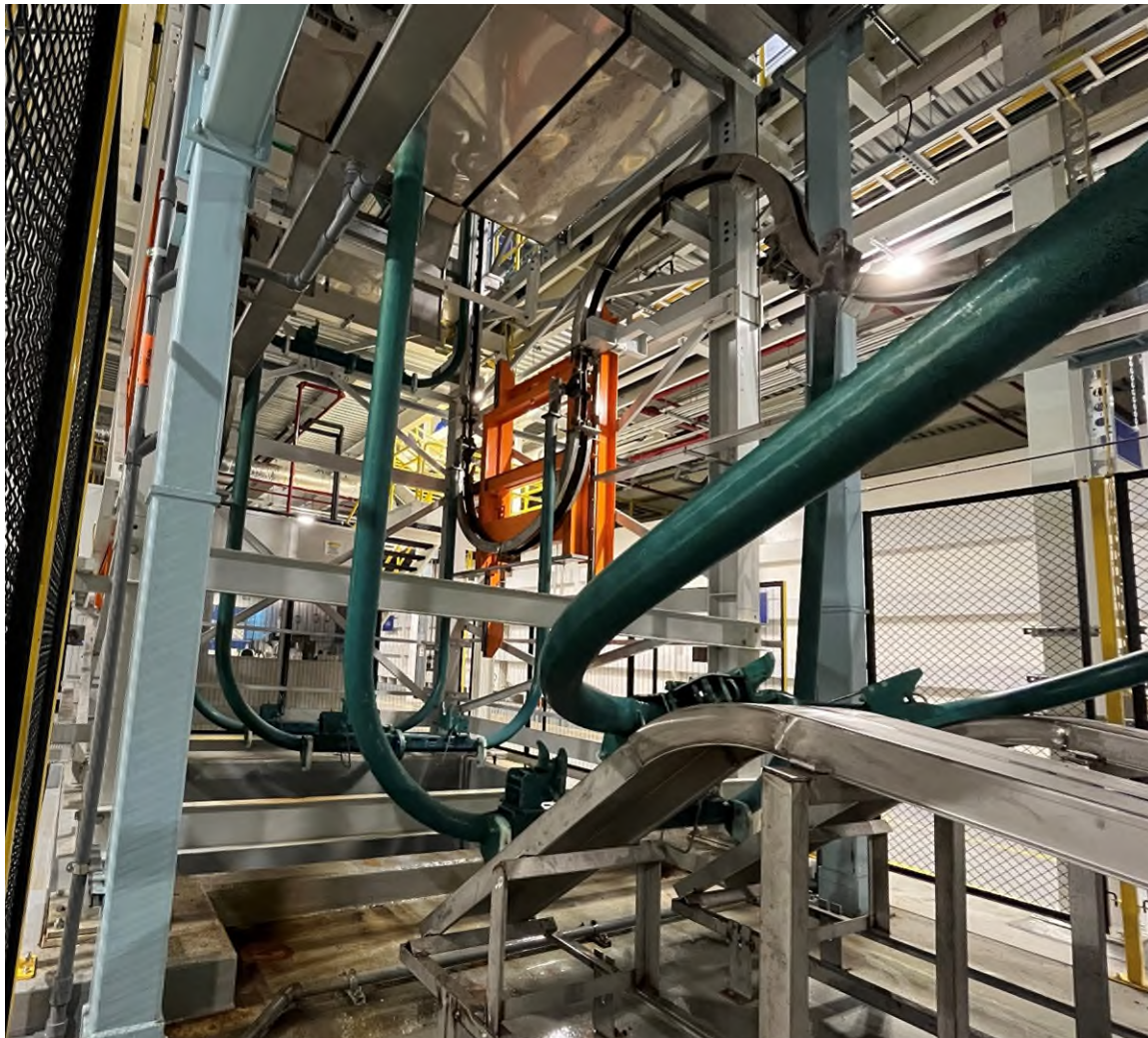

Pendulum Systems

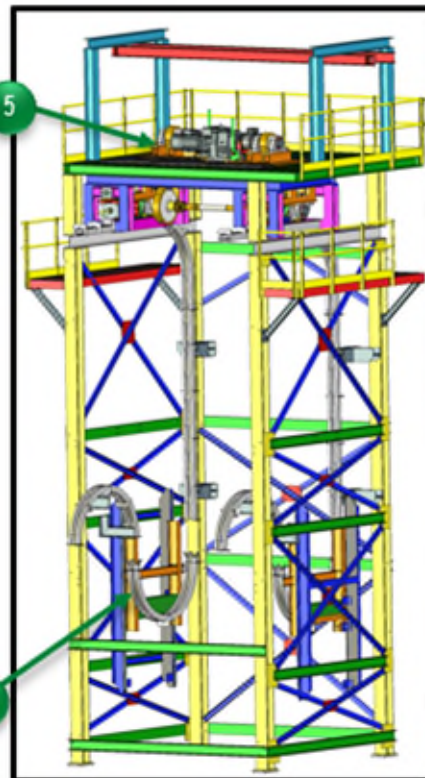
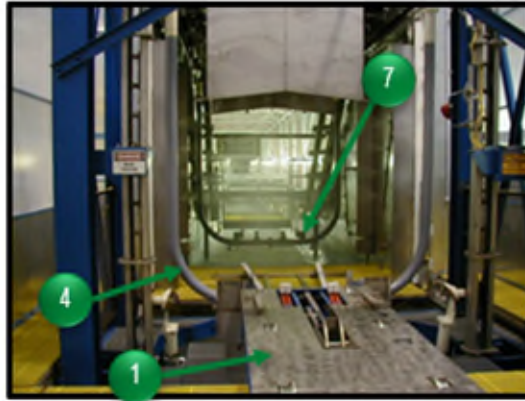

- 1 Inlet Roll Table
- 4 Penduls
- 6 Gravity Take-Up
- 2 Baths
- 5 Caterpillar Drive Units
- 7 Pendul Locking Mechanism
- 3 Outlet Roll Table

System Overview

The pendulum type conveyors are designed to carry skids with vehicle bodies through the pre-treatment and ELPO baths. The skids are picked up from an inlet roll table, then lowered into a series of baths, and finally unloaded onto an outlet roll table. The penduls that hold the skids and bodies are partially immersed in the baths, to ensure that the bodies are completely treated by the liquids.

Features of the Pendulum conveyors include:

- Caterpillar Drive Units – two units for the PT pendulum & one unit for the ED pendulum
- Two conveyor chain strands
- Penduls
- Gravity take-up system to maintain chain tension under varying load conditions
- Skid locking mechanism to hold skids on the penduls
- Skid unlocking mechanism to release skids prior to their delivery to the exit roll table
- Horizontal return run to save space
- Auto-lubrication systems for the drive, transmission, and conveyor chains
- Sensors for sending pendul location and other information to the control panel PLC

Skid/Body Lock/Unlock Assembly

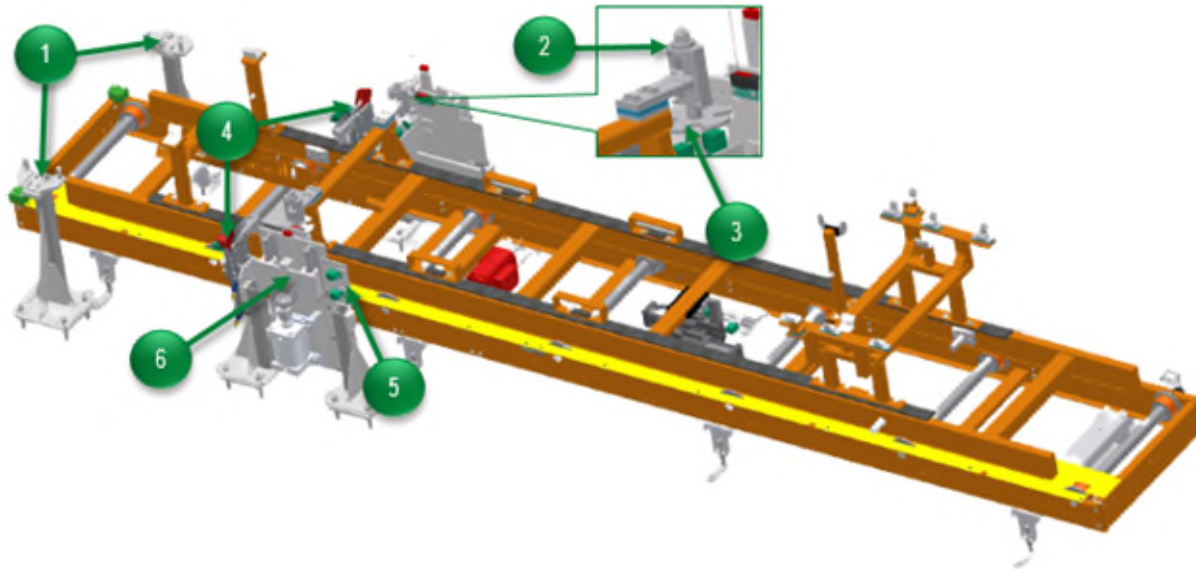

- | | | |
|---|---|---|
|  Lock Operator |  Cloverleaf Actuator |  Proximity Switches |
|  Skid Lock Pin |  Pneumatic Skid Clamps |  Pneumatic Thumper |

Skid/Body Lock/Unlock Overview

Before and after the pendulum systems, a power roll table will be equipped with a Skid/Body Lock/Unlock assembly that mounts to the sides. The purpose of this assembly is to lock/unlock the body onto/from the skid. The station with this assembly prior to the pendulum will lock the body to the skid so that it will not float off as it dips into the baths within the pendulum systems. After the pendulum system process completes, another station with this assembly will unlock the body from the skid so that the body can be transferred from the pendulum skid to the paint shop skid.



The Skid/Body Lock/Unlock assembly contains the following sub-assemblies:

Skid Locking Pin

- *Lock Operator*

The lock operator is at the entry point of the power roll table on both sides. When the skid with body enters, the pins on the operator contact the skid lock pin cloverleaf-shaped actuator to rotate the lock pin 180°. Depending on the station function, this will either lock the body to the skid or unlock it from the skid.

- *Skid Clamp*





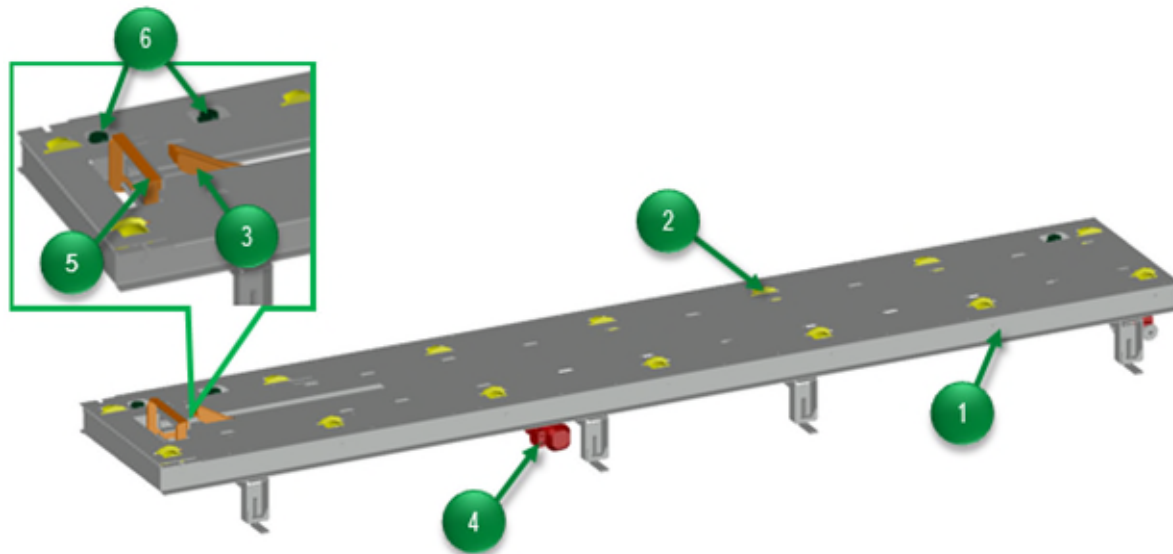

Once the skid is positioned on the power roll table, the pneumatic skid clamps on both sides of the table engage to hold the skid onto the power roll table. A pair of proximity sensors at each skid clamp tell the system if the clamp is engaged or not.

- *Thumper*

After the skid clamps are in place, a pneumatic-powered Thumper assembly extends to make contact with the underside of the body that is on skid in an attempt to raise the body. Depending on the station function, the body will either raise (unlock) or stay in place (lock).

Pendulum Inlet Table



- | | | |
|--|---|---|
|  Support Frame |  Electric Pusher |  Skid Stop |
|  Chain Driven Rollers |  Electric Pusher Motor |  Proximity Switches |

Inlet Table Overview

The pendulum conveyor inlet table is designed to feed skids to the pendulum conveyor so they can be properly picked up by the penduls. This special roll table is designed for wet area conditions and therefore the rollers are chain driven and the table has a stainless steel top cover plate. Skid staging to the pendulum conveyor is effected by moving the lead end of the skid into position for engagement with a pendul. This is done by the rollers of the table. Final staging is accomplished through the use of a pusher mechanism that is located near the discharge end of the inlet table. Skid movement on the inlet table is controlled by the PLC in the local control panel. The PLC receives information from input devices located on both the inlet table and the pendulum conveyor.



 Electric pusher engaging with a skid

Pendulum Outlet Table

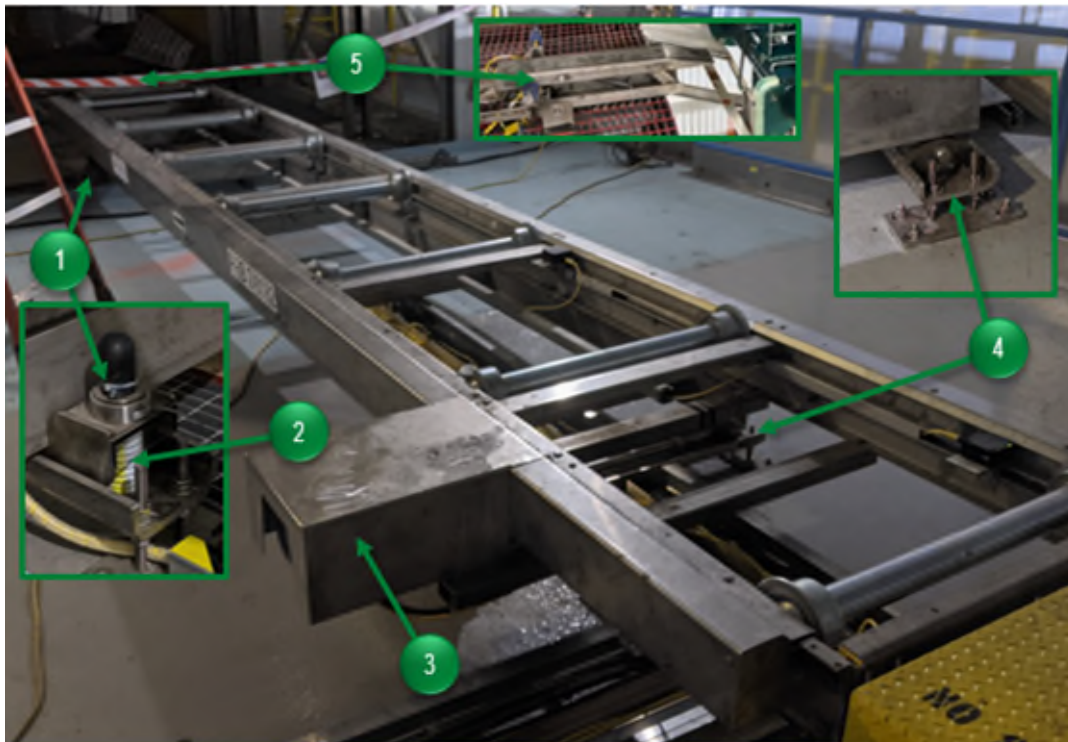

- Transducer
- Gearmotor
- Diving Board
- Spring
- Pivot Mount

Outlet Table Overview

The pendulum conveyor outlet table is designed to receive skids as they are dropped off by the penduls. From the pendulum conveyor they will be transferred into the skid conveyor system.

The table looks like a standard wet area roll table, but there are a couple key differences. At the infeed of the table, there are four spring mounts – two on each side. These spring mounts absorb the shock of the skids should they fail to detach properly from the pendul. On top of the springs are transducers that can detect a spike in pressure should a skid land directly on the table. Additionally, there is a diving board present immediately before the table. This board has a spring device that will shut down the system should something land on it.

At the gearmotor end, the table mounts to the floor with a pivot mount. This allows the vertical travel needed at the other end of the table for the springs.



Skid transfer from pendul to outlet table

Pendulum Drive Assembly

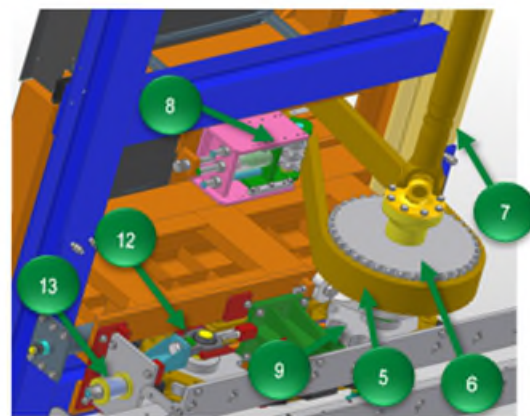
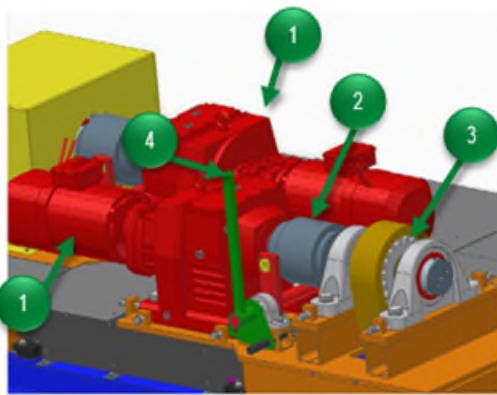
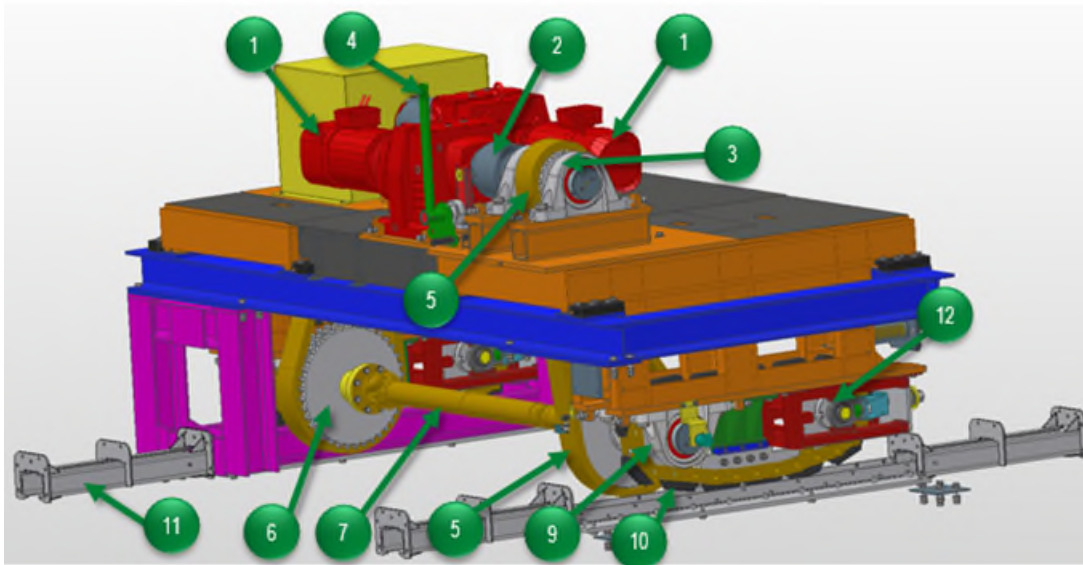

- | | | |
|---------------------|--------------------------------|---------------------------------|
| 1 Gearmotor | 6 Drive Sprocket | 10 Caterpillar Chain |
| 2 Coupling | 7 Cardan Shaft | 11 Conveyor Chain Track |
| 3 Motor Sprocket | 8 Drive Chain Spring Tensioner | 12 Caterpillar Take-Up Sprocket |
| 4 Coupler Arm | 9 Caterpillar Drive Sprocket | 13 Torque Overload Spring |
| 5 Triple Chain Loop | | |

Pendulum Drive Overview

A caterpillar drive assembly at the pendulum conveyor exit pulls the pendulum conveyor chain at both PT (Phosphate) and ED (E-Coat) pendulum systems. In the event the pendulum system has extended lengths needed for the process, a secondary mid drive unit may be implemented to assist the main drive unit.

Each caterpillar drive assembly has two 15hp SEW gearmotors: main and standby. Only one gearmotor is engaged and uses a coupling to drive the motor sprocket and ultimately drives the conveyor chain. The standby gearmotor is de-coupled from its motor sprocket and does not act upon the conveyor chain. The coupling arm (orange level) will indicate whether a gearmotor is engaged or disengaged.

The motor sprocket drives a triple chain loop that powers a drive sprocket. A drive chain spring tensioner maintains tension for the triple chain. A cardan shaft transmits power to the drive sprocket on the other side of the drive assembly. These drive sprockets in turn power the caterpillar drive sprockets that pulls the caterpillar chains on each side.



▲ Upper Caterpillar Drive Assembly – Main and Standby Drive Units



▲ Lower Caterpillar Drive Assembly – Cardan Shaft and Drive Sprocket

The caterpillar chain pulls the conveyor chain that is riding in the chain track. At the other end of the caterpillar chain loop is a caterpillar take-up sprocket that maintains caterpillar chain tension.

There are a number of controls on the drive assembly:

- Rotary encoder on one of the caterpillar motor sprockets to monitor conveyor chain speed.
- Proximity sensors at each drive unit to inform the controls system which drive unit is engaged/dis-engaged.
- Proximity sensor that determines an over-torque situation on each caterpillar drive frame.
- Vibration sensor on each gearmotor for future predictive preventive maintenance functionality.

ⓘ NOTICE ⓘ

FATA is supplying only the vibration sensors. Plants will implement the control software for the predictive preventive maintenance functionality.

Pendulum Chain

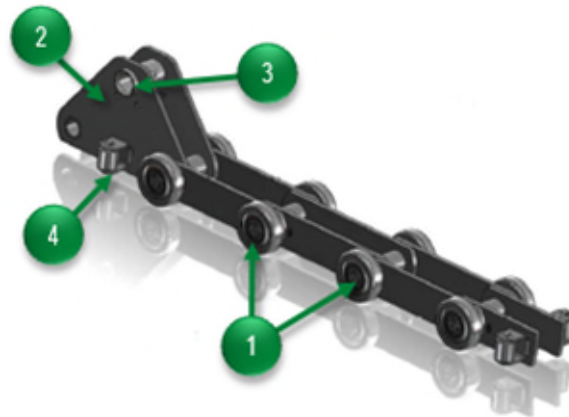

Roller Pins



First Link



Pendul Mount



Side Guide Rollers

Pendulum Chain Overview

Two sets of pendulum chains ride on the track for each pendulum system – one for each side of the pendul. One pitch of the pendulum chain allows two penduls to be mounted – one pendul per four-meter long chain segment – with each pitch made up of two segments totaling eight meters. Each segment is made up of 32 links of varying types that are all connected with roller pins that ride on the conveyor chain track.

The first link of a segment is triangular when viewed from the side. This link is where one end of a pendul mounts and has side guide rollers to keep the conveyor chain centered in the track. The remaining links are like a standard chain link except that every fourth link has side guide rollers.



▲ Pendulum Chain with a mounted pendul

Penduls

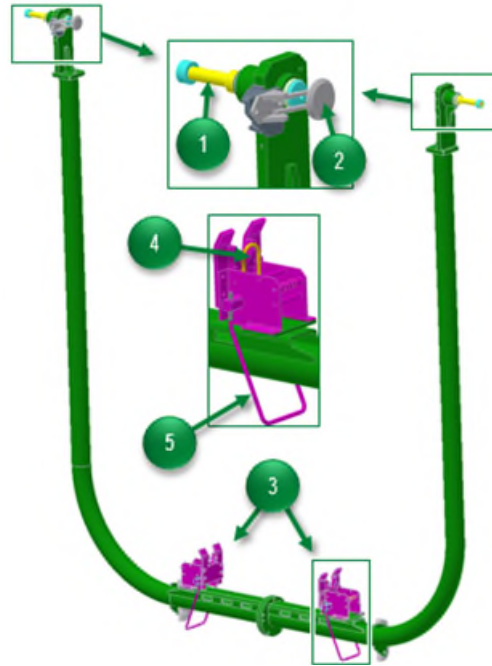

* - Current collectors are only installed in ELPO pendulum systems.

- Conveyor Chain Attachment
- Current Collector*
- Skid-Locking Mechanism
- Skid Pin
- Latch Arm

Pendul Overview

The U-shaped pendul assembly carries one end of the skid as it travels through the various baths – two penduls will carry an entire skid: front and rear. At the tips of the “U” is where the pendul attaches to the conveyor chain. The front and rear pendul function similarly, however, can be differentiated at their attachment pin locations. On the pendul for the front of the skid, there are a pair of pins at the tips to identify that this is the pendul for the front of the skid. At the tips of the rear penduls, current collectors may be mounted that electrically grounds the skid and the vehicle body that it is carrying. Current collectors are only necessary for E-Coat systems.



Mounted Current Collector



Skid-Locking Mechanism with a skid

At the base of the pendul are two skid-locking mechanisms. These mechanisms latch onto a pin on the side of the skid to ensure it is secure. This is important so that it does not come off the pendul when it is dipped into bath tanks. The latch arm can be changed to one of two positions: outward (locked) or inward (unlocked). A floor-mounted actuator is installed at the entry and exit of the pendulum booths and changes the position of latch from the skid-locking mechanism.

Pendulum Take-Up

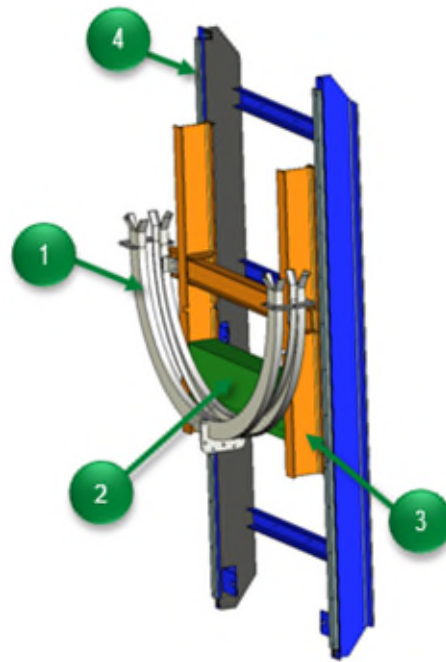

1 Floating Chain Track

2 Weights

3 Slide Mount

4 Slide Mount Track

Pendulum Take-Up Overview

As the pendulum system operates in picking up skids with the penduls, dipping the skid in and out of the bath, and then unloading skids from the penduls, the load on the conveyor chains varies. To maintain a relatively constant load on the conveyor chains, and to serve as a “shock” absorber, the pendulum uses a gravity take-up for both chains. These take-ups are on the sides in the lower half of the drive/take-up tower.

Each take-up is made up of a floating chain track that connects to a series of weights, which in turn connects to a slide mount. The slide mount rides on a track that is fixed to the drive/take-up tower structure.



▲ Gravity Take-Up external view