

Power Roll Bed Paint Application Maintenance & Service

This section will describe service procedures for major mechanical elements of a Power Roll Bed PNT.

⚠ WARNING ⚠

- Only qualified and trained personnel should perform the disassembly and assembly of electrical and mechanical components.
- Before attempting any maintenance on this equipment all involved personnel should follow plant internal regulations along with any state, federal, or province regulations. Do not begin any repair procedure until the proper shutdown procedures and the appropriate power lockout procedures have been applied.

How to Replace a Chain

- 1 Remove and lock out power to the Power Roll Bed using your plant's procedures.



- 2 Remove the covers to gain access to the chain.



- 3 Adjust the tensioner to loosen the chain.



- 4 Open the master link of the chain on both sides of the roller.



- 5 Reinstall the new chain with the master link.



- 6 Install the tensioner to a sufficient chain tension.



- 9 Place the covers back on Power Roll Bed and tighten the screws.

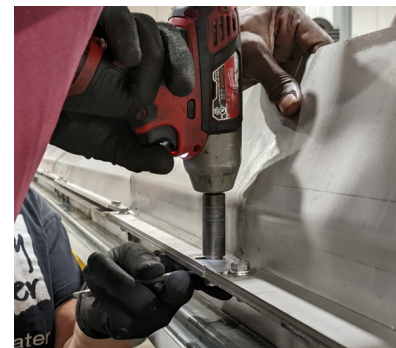

- 10 Restore power to the system and test for proper operation.



How to Replace a Roller

- 1 Remove and lock out power to the Power Roll Bed using your plant's procedures.



- 2 Remove the necessary covers.



- 3 Remove the tensioner to relieve tension on the chain.



- 4 In order to replace a roller, all adjacent rollers must be disassembled that are mounted at the respective gearmotor side.



- 5 Open the master link of the chain on both sides of the roller.



- 6 Remove the M10 screws holding the flanges on both sides of the worn roller.

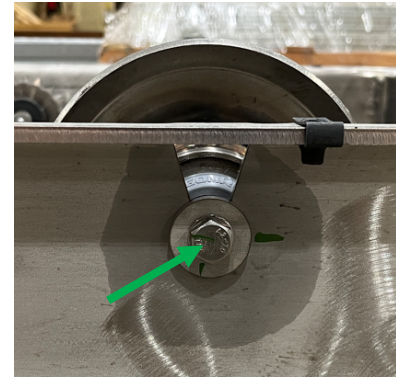

- 7 Turn around flanged bearings 90°, to get them through the cut-out of side frames. If they are clamped between side frames, you must loosen screws of drive shaft and pull bearings slightly apart, so that the carrying roller can be withdrawn upwards.



- 8 Replace the roller.

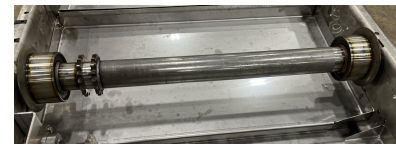

- 9 Turn the flange horizontal and install their hex-head screws



- 10** Retighten all M10 bolts firmly. Take great care that there is contact between the flange and the side frames.



- 11** Reinstall the tensioner with screws.



- 12** Place cover back on Power Roll Bed and tighten the screws.



- 9** Restore power to the system and test for proper operation.



How to Replace a Gearmotor

- 1 Remove and lock out power to the Power Roll Bed using your plant's procedures.



- 2 Support the gearmotor.



- 3 Loosen and remove necessary covers for the cardan shaft.

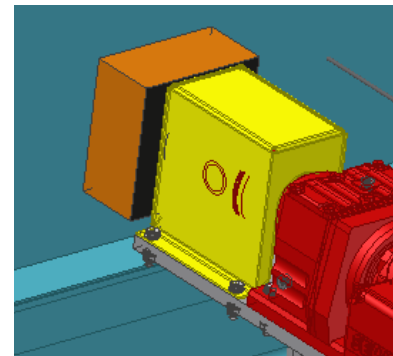

- 4 Undo the setscrews in the flange at the gearmotor end of the cardan shaft.

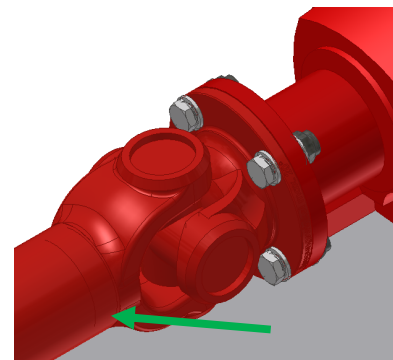

- 5 Loosen and remove the M8 bolts (4) attaching the cardan shaft to the companion flanges at the gearmotor end.

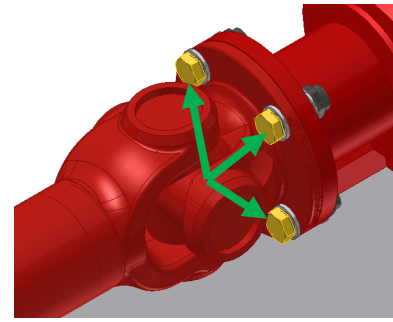

- 6 Loosen and remove the M8 mounting bolts (4) securing the motor to the pedestal.

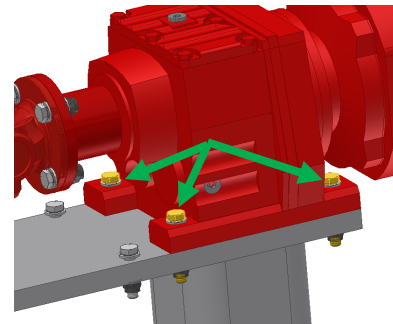

- 7 Remove the original gearmotor and replace with the new one.

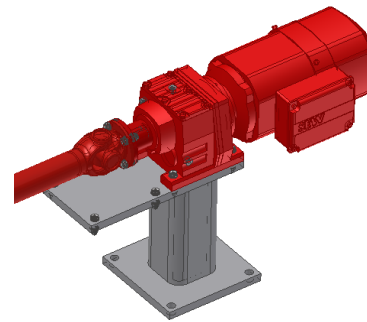

- 8 Set and tighten the M8 mounting bolts (4) to 25Nm securing the motor to the pedestal.

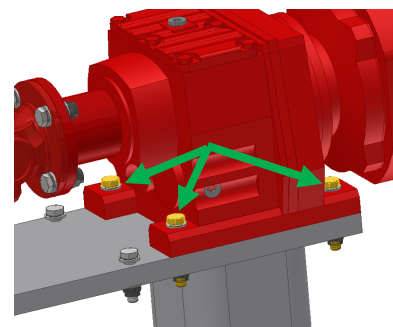

- 9 Place and tighten the M8 bolts (8) to 25Nm for the companion flanges at the gearmotor end.

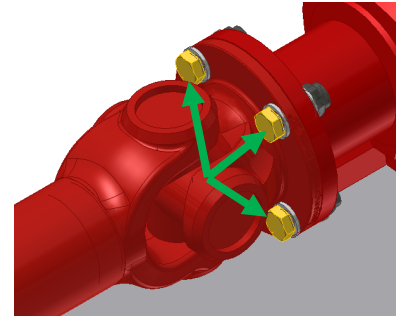

- 10 Tighten the setscrews in the flange at the gearmotor end of the cardan shaft.

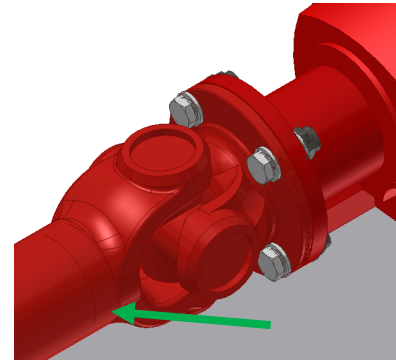

- 11 Place and tighten the covers.

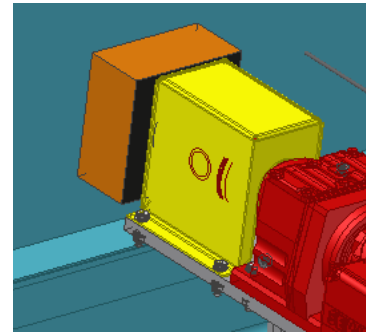

- 12 Remove the gearmotor support.



- 13 Restore power to the system and test for proper operation.



How to Replace a Cardan Shaft

- 1 Remove and lock out power to the Power Roll Bed using your plant's procedures.



- 2 Loosen and remove necessary covers for the cardan shaft.

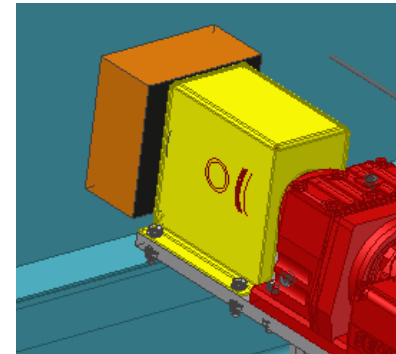

- 3 Undo the setscrews in the flange at both ends of the cardan shaft.

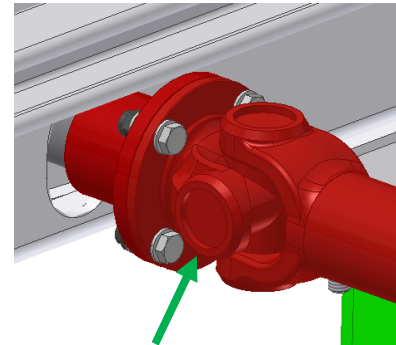

- 4 Loosen and remove the M8 bolts (8) attaching the cardan shaft to the companion flanges at both ends.

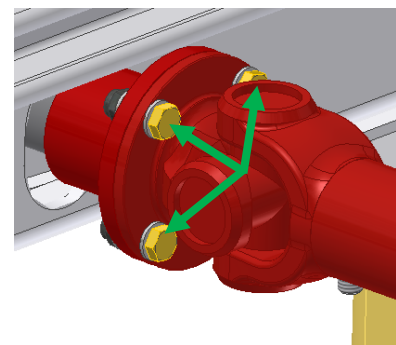

- 5 Remove and replace the cardan shaft.



- 6 Place and tighten the M8 bolts (8) for the companion flanges at both ends.

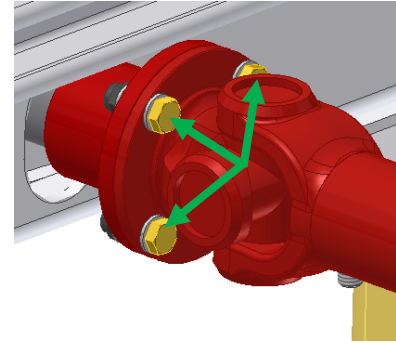

- 7 Tighten the setscrews in the flange at both ends of the cardan shaft.

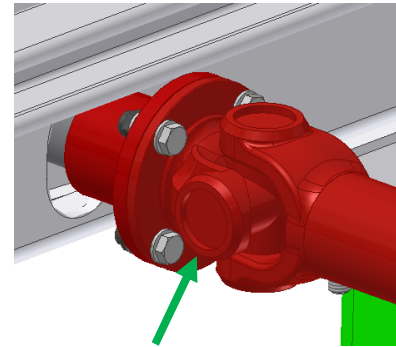

- 8 Place the covers back on.

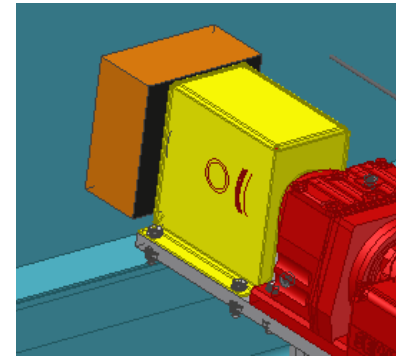

- 9 Restore power to the system and test for proper operation.

