

Safety



Typical Lockout Tag

Safety should be a primary concern for all personnel working in an industrial environment. Industrial machinery is capable of causing serious injury or death when operated improperly or when personnel are unaware of equipment status or are distracted.

While many safety features are built into controlling automated equipment, the best way to prevent accidents is for everyone to be alert, safety conscious, knowledgeable about the equipment, and use common sense.

When in doubt – Lock it out!

You should lockout and tagout equipment...

- Anytime a guard or a safety device is removed.
- When a person must place any part of their body where it could be caught by moving parts.
- Before performing maintenance.
- Before making repairs.
- During troubleshooting procedures.
- During installation new equipment.
- During removal or rework of existing equipment.

NOTICE

Prior to performing service on a conveyance system, always follow plant internal regulations along with any state, federal, or provincial regulations.

Vertical Drop Lifter Safety

Whenever you are maintaining and/or servicing the Asset, you should mechanically secure it. Use the following procedure:

⚡ ⚠ **WARNING** ⚠ ⚡

Only qualified and trained personnel should perform the disassembly and assembly of electrical and mechanical components.

Securing the Vertical Drop Lifter

- 1 Lower either the lift carriage or counterweight so that its locking slot aligns with the lock pin bracket.

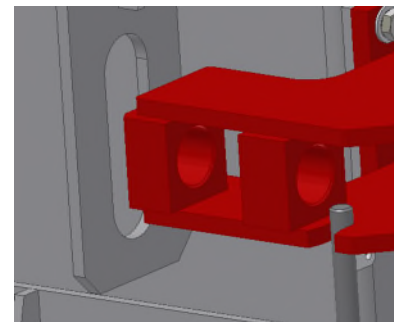

- 2 Shutdown and lockout the VDL according to plant lockout procedures.



- 3 Attach safety straps or chain from the eyebolts at the top of the VDL to the eyebolts that are at the top of the component – either lift carriage or counterweight – that is at the top of the VDL.

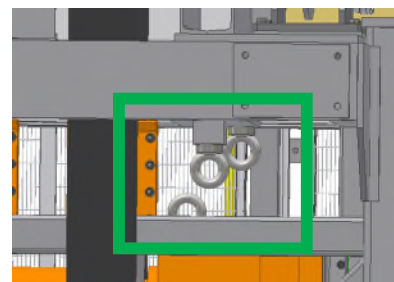

4

Move the appropriate safety pin from its stowed position on the lock pin bracket and completely insert it into the locking position on the bracket so that the end of the safety pin protrudes through the locking slot.

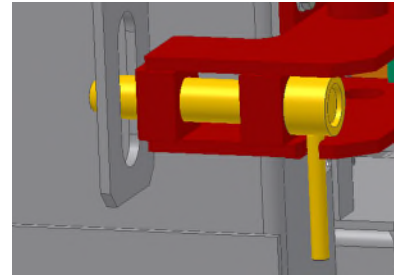
**5**

If the safety pin being used and the lock pin bracket are equipped with lock flags, insert your safety lock through the lock flags to ensure that safety pin is not prematurely removed.

