

# Skillet Turn Table – Typical Components

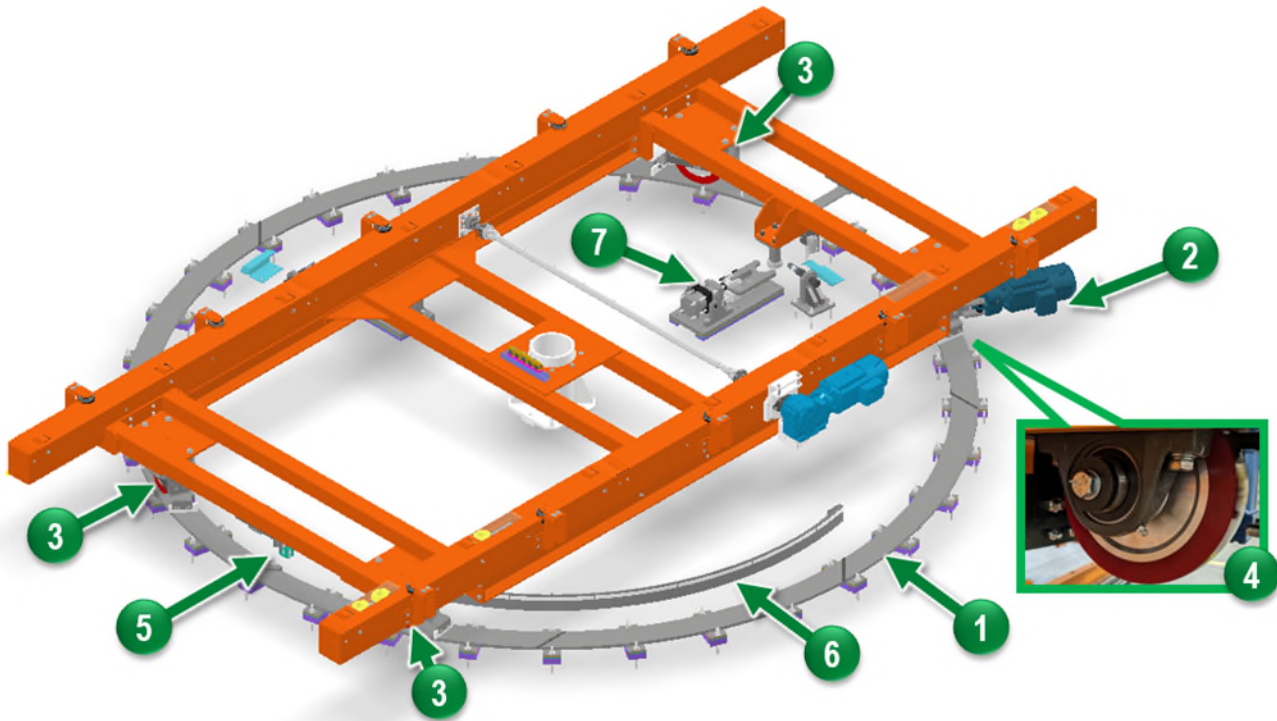

- |                         |                       |                     |
|-------------------------|-----------------------|---------------------|
| <b>1</b> Rail           | <b>2</b> Gearmotor    | <b>3</b> Idle Wheel |
| <b>4</b> Drive Wheel    | <b>5</b> Reading Head | <b>6</b> Code Rail  |
| <b>7</b> Pneumatic Lock |                       |                     |

## Turn/Pivot Table Overview

Within the broader context of a Skid Module System, Turn Tables and Pivot Tables operate as rotary platforms positioned at essential junctures along a conveyor system. Serving as a Power Roll Bed with rotational capability, these tables are designed to reorient vehicle skids to precise angles — most commonly 90°, 180°, 270°, or a full 360° — to facilitate a variety of process requirements.

The rotation may be needed to adjust the orientation of the vehicle body for subsequent assembly stations, optimize the layout of intersecting conveyor lines, or enhance space efficiency within the plant. By enabling controlled rotation, these platforms allow robot cells and workstations to access different sides of the vehicle, thereby streamlining process sequencing.

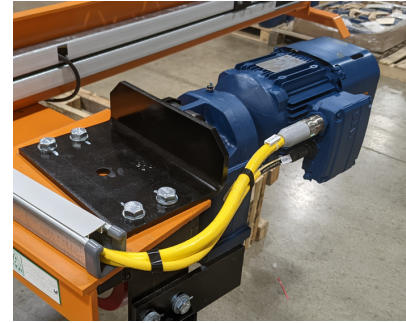

▲ Mounted Turn Table gearmotor.

Turn Tables and Pivot Tables are structurally differentiated by the position of their bearing mounts: Turn Tables feature a central turn radius, while Pivot Tables position the bearing off-center, near the table's end section. Both utilize standard wheel blocks made of vulcanized rubber, directly driven by gearmotors equipped with hollow shafts and torque supports. These supports are anchored to the cross beam with rubber buffers, end stops, and cam switches that are strategically arranged to precisely define the table's turn area.

Rotation requirements are generally based on:

- **Orientation Adjustment:** Certain assembly operations require the vehicle body to face a specific direction. For example, when entering a different phase of a paint shop process, the body may need to be rotated 180 degrees from its incoming position to function properly in the next phase.
- **Line Layout Optimization / Space Efficiency:** Conveyor lines in automotive plants often intersect or curve to maximize space utilization. A Turn or Pivot Table enables the skid to negotiate these changes in direction without manual intervention. By allowing the conveyor to change direction, it helps make optimal use of limited floor space.
- **Process Sequencing:** Multiple robot cells or workstations may be arranged in a way that necessitates periodic rotation of the vehicle body for access to different sides.

Turn and Pivot Tables can be customized to:

- Accommodate different skid sizes and weights
- Include multiple rotation angles (e.g., programmable stops at 90°, 180°, 270°, and 360°)
- Integrate with lifts for vertical movement
- Feature locating pins for precise skid positioning

The typical operational sequence of a Turn or Pivot Table in a Skid Module System is as follows:

- As the skid approaches, sensors confirm its arrival and readiness for rotation.
- The skid stops, devices engage, and the skid transfers to the platform.
- The control system verifies safety conditions and proper loading, ensuring no personnel are in the hazard zone.
- The motor activates, rotating the platform to the required angle.
- Position sensors confirm alignment.
- The conveyor resumes, moving the skid onward in its new orientation.

# Skillet Power Roll Bed Typical Components

(Mounted on Turn Table)

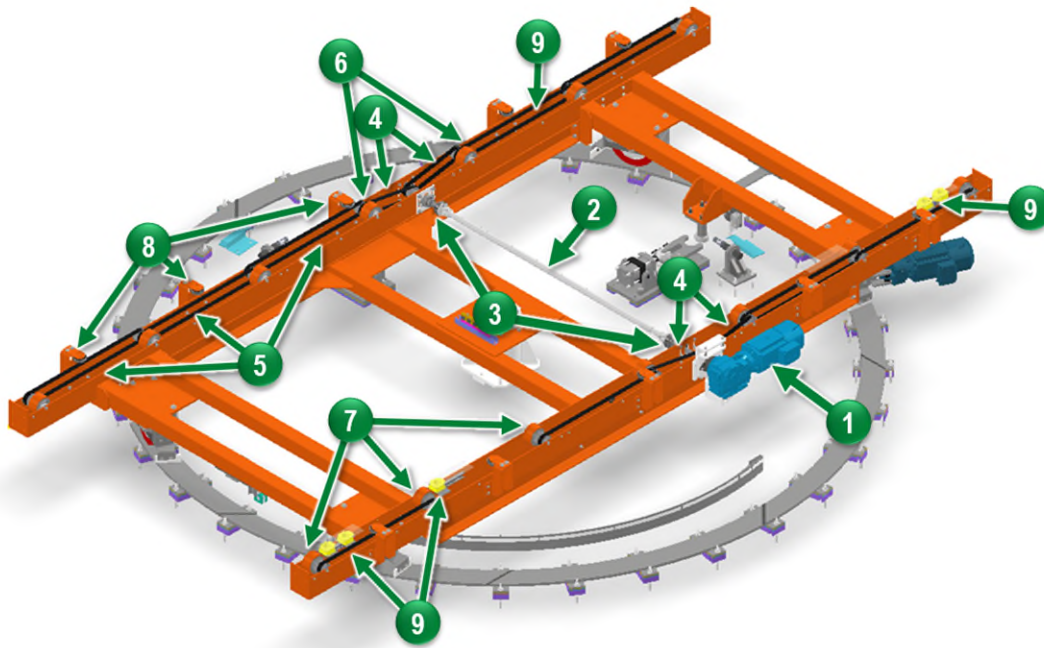

▲ Skillet Power Roll Bed shown with safety covers removed.

|                  |                |                               |
|------------------|----------------|-------------------------------|
| 1 Gearmotor      | 2 Cardan Shaft | 3 Drive/Driven Shaft Assembly |
| 4 Drive Belts    | 5 Driven Belts | 6 Drive Rollers               |
| 7 Driven Rollers | 8 Side Guides  | 9 Sensors                     |

## Skillet Power Roll Bed Overview

Power Roll Beds are a major element of FATA Automation's Skid Conveyor Systems. The products are modular in design using common components such as motors, belts, rollers, switches, cords, and trunk cables as a complete package.

The side frame of a Skillet Power Roll Bed is made of bended C-profile that mounts the carrying rollers.

The gearmotor is connected to adjacent drive rollers with its double tooth pulley fitted to the motor shaft and they in turn are connected to the driven rollers and timing belts to transport skids along the table.

The "Skillet" Power Roll Bed features a cardan shaft connected to the drive shaft which connects to the opposite end of the frame, which features another shaft assembly to turn more sets of rollers and belts.

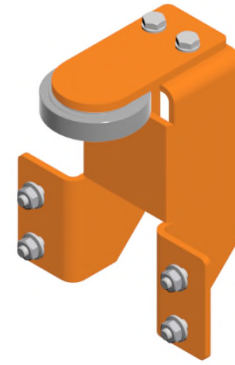

▲ Side-mounted guide wheel

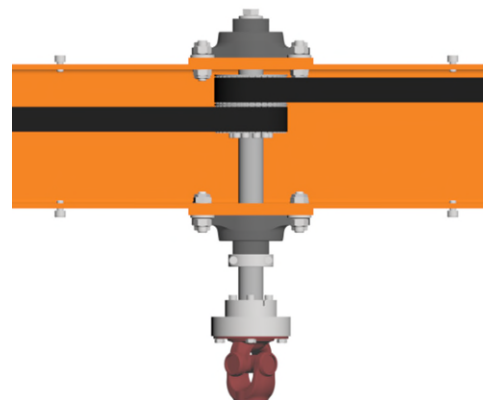

▲ Top-down view of driven-side shaft assembly.

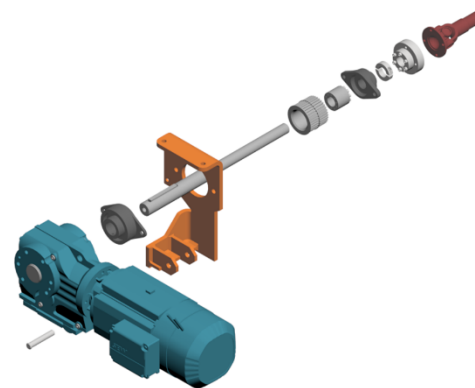

▲ Exploded view of motor-side drive shaft assembly.